



# MILADY DG

## Product Data

## Digital mammographic equipment

**MILADY DG** is a complete digital mammography system optimized for 2D image acquisition, fully upgradable to any digital method: tomosynthesis and dual energy (predisposed for a future implementation). It can be completed with a wide range of accessories including the device for stereotactic and tomoguided biopsies. It is composed of mammography unit with isocentric C-arm, integrated high voltage generator, biangular X-ray tube, full field digital detector equipment and integrated or separate Acquisition Work Station (AWS).

### X-RAY HIGH-VOLTAGE GENERATOR

Line voltage compensation	Automatic: H.V. generator with kV closed loop and line feed forward compensation
Inverter technology	Current fed, Mosfet bridge with output current limit capability and short circuit protection
Inverter frequency	50 kHz
Ripple frequency/amplitude	100 kHz < 2 %
Generator output power	7.4 kW (@ 37 kV)
kV range	Standard: 20 ÷ 35 kV Optional: 20 ÷ 49 kV
kV resolution (all modalities)	0.5 kV
kV precision	± 1 %
kV repeatability	± 0.1 %
kV risetime	≤ 1.5 ms from 0 to 100 %
kV display	XX,X kV (3 digits)
Lowest current time product (IEC 60601-2-45:201.7.9.2.1.f)	1 mAs
mAs maximum value	640 mAs (allowed)
mAs resolution (automatic)	0.1 mAs
mAs values	In accordance with R'20 series (Note: values rounded down on the base of standards tolerance and series limited to 640 mAs)
mAs display	XXX,X mAs (4 digits)
Exposure time range	0.02 ÷ 4.7 s (640 mAs @ 135 mA)   Automatically selected in function of selected mAs
Safety timer	10 s



# MILADY DG

## Product Data Digital mammographic equipment

### X-RAY TUBE - IAE XM1016T

Anode rotation speed	3000 r.p.m. @ 50 Hz 10000 r.p.m. @ 50 Hz (optional)
Target material	Tungsten Focal track: RT (Tungsten + Rhenium) Bulk: TZM (Molibdenum + Titanium + Zirconium)
Anode heat storage capacity	300 kHU (225 kJ)
Maximum anode heat dissipation rate	60 kHU/min (750 W)
X-ray tube assembly heat storage capacity	500 kHU (375 kJ)
X-ray tube assembly heat dissipation rate	108 HU/s (80 W)
Cooling method	Free air convection
Anode disc target angle	10° (small focus) / 16° (large focus)
Anode disc diameter	80 mm
Focal spots	2
Focal spot size according to IEC 336	0.1x0.1 mm (small focus) / 0.3x0.3 mm (large focus)
Power (nominal anode input power)	1400 W (small focus) / 5600 W (large focus) (3000 r.p.m.) 2400 W (small focus) / 9600 W (large focus) (10000 r.p.m.)
Nominal X-ray tube voltage and highest X-ray tube current available at that voltage (IEC 60601-2-45:201.7.9.2.1.a)	Large focus 35 kV @ 90 mA (optional 40 kV @ 90 mA) (3000 r.p.m.) 35 kV @ 90 mA (optional 40 kV @ 90 mA) (10000 r.p.m.)
Highest X-ray tube current and highest X-ray tube voltage available at that current (IEC 60601-2-45:201.7.9.2.1.b)	Large focus 90 mA @ 35 kV (optional 90 mA @ 40 kV) (3000 r.p.m.) 90 mA @ 35 kV (optional 90 mA @ 40 kV) (10000 r.p.m.)
Corresponding combination of X-ray tube voltage and current which results in the highest electric output power (IEC 60601-2-45:201.7.9.2.1.c)	Large focus (3000 r.p.m.) 35 kV @ 90 mA = 3150 W (optional 40 kV @ 90 mA = 3600 W) Large focus (10000 r.p.m.) 35 kV @ 90 mA = 3150 W (optional 40 kV @ 90 mA = 3600 W)
Lowest current time product (IEC 60601-2-45:201.7.9.2.1.f)	1 mAs (for all kV values)
For mammographic X-Ray equipment provided with automatic exposure control controlling loading time, shortest loading time and/or the lowest resulting current time product (IEC 60601-2-45:201.7.9.2.1.h)	8 mAs (using 20 mm PMMA phantom)
X-ray window	0.5 mm Beryllium
Housing X-ray protection	≥ 0.5 mm Pb equivalent
Inherent filtration	0.0 mm Al (IEC 60522:1999-02)
HVL measured at 28 kV	> 0.5 mm Al eq.
Total filtration at 28 kV	> 0.5 mm Al
<b>Tube assembly thermal overload protection</b>	
With active temperature sensor under main CPU control	Upper limit temperature 65° outside tube assembly HU and °C display available in technical menu
<b>Filters</b>	
50 µm Rhodium (Rh)	0.51 mm Al eq. 28 kV (measured with Tungsten target)
50 µm Silver (Ag)	0.54 mm Al eq. 28 kV (measured with Tungsten target)
500 µm Aluminium (Al) (active only in tomo mode)	0.4 mm Al eq. 28 kV (measured with Tungsten target)
700 µm Aluminium (Al) (optional and active only in tomo mode)	0.51 mm Al eq. 28 kV (measured with Tungsten target)
300 µm Copper (Cu) (optional, predisposition for future Dual Energy implementation)	3.85 mm Al eq. 28 kV (measured with Tungsten target)



# MILADY DG

## Product Data **Digital mammographic equipment**

### AUTOMATIC COLLIMATION DEVICE

Type	Automatic recognition of compression paddle format and position
Light source	LED (Risk group 1 - Low risk - according to IEC 62471)
Light beam	Switch ON by push-button or automatic when operating compression (selectable by service)
	Electronic timer
Light intensity	≥ 150 lux
Light beam collimation accuracy	According to IEC 60601-2-45:203.8.5.4
Mirror	With automatic out of field function
Image formats	24x30 cm 18x24 cm 14x30 cm 12x30 cm 11x30 cm 10x24 cm 11x14 cm 9x13 cm 8x11 cm 7x7 cm 8x5/7x5 cm for biopsy Trapezoidal dynamic for tomo exam (optional)
Protection of examination field	Protective screen to keep patient's face out of X-ray beam during 2D exam Extended protective screen to keep patient's face out of X-ray beam during tomo exam (optional)



# MILADY DG

## Product Data Digital mammographic equipment

### DIGITAL FLAT PANEL DETECTOR - Option nr. 1 | Model a-Si

Detector technology	(a-Si) TFT Array + Pin photodiode Amorphous Silicon
Case dimensions	35.9x34.6 cm
Top cover	Carbon fiber 0.1 mm Al equivalent
Chest gap	3.9 mm
Cooling method	Air + Fan (integrated)
Digitalization type	Logarithmic
Pixel dimension	85x85 $\mu$ m
Pixel dimension in tomo reconstructed slices (with optional tomo upgrade kit)	85x85 $\mu$ m (with any scan angle)
Pixel dimension in syntethic 2D images (with optional tomo upgrade kit and "M-VIEW/VI" software)	85x85 $\mu$ m
Active area	23.9x30.5 cm (24x30 cm format)
Image matrix	2816x3584=10092544 pixels
Image depth	16 bit
Fill factor	80 % geometric
MTF (Modulation Transfer Function)	> 75 % @ 1 lp/mm > 10 % @ 5.8 lp/mm
DQE (Detector Quantum Efficiency) for an exposure of 28 kV	> 45 % @ 1 lp/mm > 10 % @ 5.8 lp/mm
Resolution	5.9 lp/mm (Nyquist)
Signal to Noise Ratio (SNR) (with 45 mm PMMA phantom)	15.19 (28.5 kV - 10 mAs)
Ghost image factor (point n° 2b.2.4.5 of "EUREF")	0.05
Tomosynthesis acquisition time (activated with optional tomo upgrade kit)	5 s (with 15° scan angle) 6 s (with 24° scan angle) 11.5 s (with 50° scan angle)
Reconstruction time from last exposure (breast thickness of 50 mm)	<15 s (in 2D mode) Tomo mode (all slices) (optional) 36 s (with 15° scan angle) 38 s (with 24° scan angle) 49 s (with 50° scan angle) Tomo mode (slab of 10 mm) (optional) 13.5 s (with 15° scan angle) 15.5 s (with 24° scan angle) 26.5 s (with 50° scan angle)
Time between two images acquired successively (breast thickness of 50 mm)	<15 s (in 2D mode) Tomo mode (optional) 36 s (with 15° scan angle) 38 s (with 24° scan angle) 49 s (with 50° scan angle)



# MILADY DG

## Product Data Digital mammographic equipment

### DIGITAL FLAT PANEL DETECTOR - Option nr. 2 | Model a-Se

Detector technology	Amorphous Selenium (a-Se)
Selenium thickness	200 µm
Case dimensions	35.9x34.6 cm
Top cover	Carbon fiber 0.1 mm Al equivalent
Chest gap	3.9 mm
Cooling method	Air + Fan (integrated)
Digitalization type	Logarithmic
Pixel dimension	85x85 µm
Pixel dimension in tomo reconstructed slices (with optional tomo upgrade kit)	85x85 µm (with any scan angle)
Pixel dimension in syntethic 2D images (with optional tomo upgrade kit and "M-VIEW/VI" software)	85x85 µm
Active area	23.9x30.5 cm (24x30 cm format)
Image matrix	2816x3584=10092544 pixels
Image depth	16 bit
Fill factor	88 % geometric
MTF (Modulation Transfer Function)	> 90 % @ 1 lp/mm > 40 % @ 5.8 lp/mm
DQE (Detector Quantum Efficiency) for an exposure of 28 kV	> 50 % @ 1 lp/mm > 20 % @ 5.8 lp/mm
Resolution	5.9 lp/mm (Nyquist)
Signal to Noise Ratio (SNR) (with 45 mm PMMA phantom)	15.19 (28.5 kV - 10 mAs)
Ghost image factor (point n° 2b.2.4.5 of "EUREF")	0.05
Tomosynthesis acquisition time (activated with optional tomo upgrade kit)	With 15° scan angle: 2.5 s for a-Se F   10 s for a-Se S With 24° scan angle: 4 s for a-Se F   12 s for a-Se S With 50° scan angle: 7.7 s for a-Se F   30 s for a-Se S
Reconstruction time from last exposure (breast thickness of 50 mm)	<15 s (in 2D mode) Tomo mode (all slices) (optional) 36 s (with 15° scan angle) 38 s (with 24° scan angle) 49 s (with 50° scan angle) Tomo mode (slab of 10 mm) (optional) 13.5 s (with 15° scan angle) 15.5 s (with 24° scan angle) 26.5 s (with 50° scan angle)
Time between two images acquired successively (breast thickness of 50 mm)	<15 s (in 2D mode) Tomo mode (optional) 36 s (with 15° scan angle) 38 s (with 24° scan angle) 49 s (with 50° scan angle)



# MILADY DG

## Product Data Digital mammographic equipment

### “SensROI” AUTOMATIC EXPOSURE CONTROL

Controlled parameters	Auto kV / Auto mAs (Zero Point Mode) Manual kV / Auto mAs (One Point Mode)
Auto parameters selection criteria	Dual mode: PRE and FAST PRE: tissue composition based (parameters evaluated by short X-Ray exposure) FAST: compressed breast thickness based
Sensitive area (only for PRE mode)	Automatically selected in function of employed compression paddle

### “POEt” POST-PROCESSING ALGORITHM

Type	Specific for mammography to optimize the quality of acquired images
Description	Processing of acquired RAW images and display in “For Presentation” format to enhance breast tissue structures and reduce the noise
Dedicated filters	For geometric magnification and in case of prosthesis, metallic clips, surgical markers, clusters of microcalcifications, breast specimens and surgical anatomical parts
Images compression format	JPEG LOSSLESS (JL) JPEG 2000 LOSSLESS (J2L)
Images saving/export format	DICOM FOR PROCESSING FFDM DICOM FOR PROCESSING (only in tomo mode)

### OPTIONAL TOMOSYNTHESIS ACQUISITION

Number of X-ray exposures (projections with constant angle span)	11 (with 15° scan angle) 13 (with 24° scan angle) 19 (with 50° scan angle)
Reconstruction method	Back-projection technique with incorporated iterative technique to improve image quality and remove artifacts
COMBO procedure	Function that allows a 2D + tomosynthesis acquisition with a single breast compression
Distance between reconstructed slices	1 mm
Tomo acquisition control	Push-button with spiral cable Push-buttons on AWS (with AWS upgrade kit) Foot-control (optional)

### OPTIONAL RECONSTRUCTION SOFTWARE OF SYNTHETIC VIEW FROM TOMO EXAM

Name	“M-VIEW/VI”
------	-------------

### GRID

Type	Linear, vibrating
Interspace material	Carbon based polymer
Ratio	6:1
Lines/cm	36
Contrast factor	1.54

### GRID (supplied with optional tomo upgrade kit)

Type	Linear, vibrating
Interspace material	Graphite
Ratio	5:1
Lines/cm	102
Contrast factor	1.3



# MILADY DG

## Product Data

## Digital mammographic equipment

### OPTIONAL DEVICE FOR GEOMETRIC MAGNIFICATION

Type	Gridless, interchangeable with Potter Bucky
Magnification ratio	x1.5 / x1.8 / x2
Small focus selection	Automatic once fitted

### IMAGE QUALITY

Spatial resolution	Conformity with "European Guidelines for Quality Assurance in mammography screening", 4 <sup>th</sup> edition and with "Recommended specifications" for Quality Assurance in mammography of American College of Radiology
--------------------	---

### DOSE CALCULATOR

Method of calculation	Average Glandular Dose (AGD) according to "D.R. Dance et al."
Data visualization (mGy)	On Acquisition Work Station (AWS)
Method of recording	Image Header (DICOM)
AGD with a 4 cm PMMA phantom (2D)	1.40 mGy
AGD with a 4 cm PMMA phantom (TOMO) (with optional tomo upgrade kit)	At 15°: 1.60 mGy for a-Se   1.50 mGy for a-Si At 24°: 2.20 mGy for a-Se   2.20 mGy for a-Si At 50°: 2.30 mGy for a-Se   2.30 mGy for a-Si
Dose limits	According to European Protocol for Dosimetry and EUREF protocol

### "Smart µPress" COMPRESSION SYSTEM

Compression paddle movement	Motor driven or manual with fine adjustment
Standard compression paddles	24x30 cm for normal breasts 18x24 cm with lateral shifting for small breasts
Optional compression paddles	24x30 cm for tomo exams (with tomo upgrade kit) 9x21 cm for magnification Ø 7,5 cm spot for magnification 18x24 cm with Ø 7,5 cm spot for contact examination 10x24 cm for axillary examination 18x24 cm with holes for 2D biopsy
Compression paddle holder	Fast mechanical unlock by rotating knob Right lock warning LED
Maximum free space available between compression plate and top cover of Potter Bucky or magnification device	182 mm with shifted compression paddles In magnification mode with specific compression paddle: 183 mm @ 1.5x 123 mm @ 1.8x 83 mm @ 2x
Compression force range	Adjustable from 70 to 200 N
Compression force displayed	Effective applied force with 1 N resolution
Compression thickness accuracy	± 1 mm
Compression paddle descent speed	4 cm/s at the start, proportionally decreasing compressing the breast
Maximum compression force safety device	Triple: electronic, electro-mechanical, mechanical
Soft compression paddle release after exposure	Selectable from control panel
Compression paddle aluminium equivalence	< 0.2 mm Al (0.135 mm Al $\cong$ 30 kV)

### ROTATING CONTROLLERS FOR COMPRESSION WITH FINE ADJUSTMENT

Number and type	Two rotating wheels with central push-button on both sides of C-Arm
-----------------	---



# MILADY DG

## Product Data

## Digital mammographic equipment

### TOUCHSCREEN COLOR DISPLAYS

Number and type	Two LED backlight touchscreens on both sides of C-Arm
Screen size (aspect ratio) and resolution	7" (4:3) - 640x480
Displayed parameters	Compression force, compressed breast thickness, patient name, projection angle, breast laterality, ACR code, collimation format, magnification factor

### FOOT-CONTROLS

Number and type	One with four pedals and one push-button Two with four pedals and one push-button (optional)
Control actions	Vertical movement of C-Arm Vertical movement of compression paddle Motor driven compression unlock
Protection degree according to IEC 529	IP X2

### EMERGENCY STOPS

Number and Type	Two red push-buttons on both sides of mammography unit One red push button on optional separate AWS
Function	To switch totally off the power of mammography unit except PC and logic interfaces (safety to close/save studies and switch off the unit)

### ISOCENTRIC C-ARM

F.D.D. (Focus Detector Distance)/S.I.D.	66 cm
Motorized movements	Rotation and vertical translation ± 15° Rotation (only with Bym 3D DMD)
C- Arm rotation range	± 180° (CW, CCW continuous to any position)
Rotation speed	20°/s with acceleration and deceleration ramp for smooth operation
C-Arm vertical range (Floor-Potter Bucky table)	54 ÷ 145 cm (travel of 91 cm)
Vertical movement speed	5 cm/s
Projection Preset positions	N° 5 programmable projections (LAT, OBL, CC, OBL, LAT)
Tomosynthesis scan angles ( <i>activated only with tomosynthesis upgrade kit</i> )	± 7,5° (15°) ± 12° (24°) ± 25° (50°)

### CONTROL SWITCHES

Number and type	Three multiswitches (five push-buttons) Two on both sides of C-Arm and one on top of X-Ray tube cover
Control actions	Vertical movement of C-arm Continuous rotation of C-arm Switch-on of collimation light

### INTEGRATED ACQUISITION WORK STATION (AWS): PERSONAL COMPUTER

Operating System	Windows 10 IoT Enterprise
CPU	Intel Core i5-6500 (Quad Core) 3.2 GHz
RAM	8 GB (16 GB with optional tomo upgrade kit)
HDD	128 GB SSD for Operating System, DMD Acquisition Software and DMD Toolkit Software (256 GB SSD optional) 1 TB SATA for images storage (≅ 25.000 images) (2 TB SATA optional)
Pointing and selection device	Keyboard with integrated touchpad
CD/DVD recorder	24x
USB port	1 (3.1)
Power pack	250 W





# MILADY DG

## Product Data Digital mammographic equipment

### INTEGRATED ACQUISITION WORK STATION (AWS): 2 MP (STANDARD), 3 OR 5 MP (OPTIONAL) COLOR MONITOR

Technology	TFT color LCD
Screen size (aspect ratio) and resolution	24" (2 MP), 21.3" (3 MP), 21.3" (5 MP) 1920x1200 (2 MP), 2048x1536 (3 MP), 2800x2100 (5 MP)
Viewing angle	178° (horizontal and vertical)
Response time	7 ms (2 MP), 20 ms (3 MP), 12.5 ms (5 MP)
Brightness	600 cd/m <sup>2</sup> max - 350 cd/m <sup>2</sup> DICOM calibrated (2 MP) 900 cd/m <sup>2</sup> max - 500 cd/m <sup>2</sup> DICOM calibrated (3 MP) 1000 cd/m <sup>2</sup> max - 500 cd/m <sup>2</sup> DICOM calibrated (5 MP)
Contrast ratio	1000:1 typical (2 MP), 1400:1 typical (3 and 5 MP)

### SEPARATE ACQUISITION WORK STATION (AWS): PERSONAL COMPUTER (integrated in mammo unit)

Operating System	Windows 10 IoT Enterprise
CPU	Intel Core i5-6500 (Quad Core) 3.2 GHz
RAM	8 GB (16 GB with optional tomo upgrade kit)
HDD	128 GB SSD for Operating System, DMD Acquisition Software and DMD Toolkit Software (256 GB SSD optional) 1 TB SATA for images storage (≅ 25.000 images) (2 TB SATA optional)
Power pack	250 W

### SEPARATE ACQUISITION WORK STATION (AWS): CONSOLE WITH TRANSPARENT ANTI-X PROTECTION BARRIER

Pb equivalence	> 0,34 mm @ 35 kV/0,26 mm @ 49 kV (IEC 60601-2-45) (thickness of 20 mm) > 0,5 mm up to 150 kV (optional) (thickness of 11 mm)
Pointing and selection device	Keyboard and mouse or touchscreen on 15" color display
CD/DVD recorder	24x
USB port	1 (3.1)
Dimensions	857x2003x640 mm
Weight	90 kg (0.34 mm Pb eq) 56 kg (0.50 mm Pb eq)

### SEPARATE ACQUISITION WORK STATION (AWS): COLOR DISPLAY (optionally available in touchscreen version)

Technology	Active matrix TFT LCD
Screen size (aspect ratio) and resolution	15" (4:3) - 1024x768
Viewing angle	160° horizontal/150° vertical
Brightness	300 nits
Contrast ratio	800:1

### SEPARATE ACQUISITION WORK STATION (AWS): 2 MP (STANDARD), 3 OR 5 MP (OPTIONAL) COLOR MONITOR

Technology	TFT color LCD
Screen size (aspect ratio) and resolution	24" (2 MP), 21.3" (3 MP), 21.3" (5 MP) 1920x1200 (2 MP), 2048x1536 (3 MP), 2800x2100 (5 MP)
Viewing angle	178° (horizontal and vertical)
Response time	7 ms (2 MP), 20 ms (3 MP), 12.5 ms (5 MP)
Brightness	600 cd/m <sup>2</sup> max - 350 cd/m <sup>2</sup> DICOM calibrated (2 MP) 900 cd/m <sup>2</sup> max - 500 cd/m <sup>2</sup> DICOM calibrated (3 MP) 1000 cd/m <sup>2</sup> max - 500 cd/m <sup>2</sup> DICOM calibrated (5 MP)
Contrast ratio	1000:1 typical (2 MP), 1400:1 typical (3 and 5 MP)



# MILADY DG

## Product Data Digital mammographic equipment

### POWER SUPPLY REQUIREMENTS

Line voltage	115/220/230/240 Vac $\pm 10\%$ 50/60 Hz
Power	For 115/220/230/240 Vac: Momentary: 85/45/43/41 A Long-time: 2.5/1.3/1.2/1.2 A
Number of phases	1 or 2 configurable
Connection	Permanently installed (IEC 60601-1)
Wall connection	20 A Thermal-magnetic circuit breaker (40 A Thermal-magnetic circuit breaker in 115 Vac option)
Mains resistance	$< 0.50 \Omega$

### CLASSIFICATION (IEC 60601-1)

Protection against electric shock	Class I, with type B applied parts
Applied parts	Potter Bucky/Biopsy Device carbon fiber Compression paddles Magnification device
Protection degree according to IEC 529	IP X0 (Mammo Unit) IP X2 (Foot-controls)
Degree of safety in the presence of flammable anesthetics mixture with air or with oxygen or with nitrous oxide	Not suitable for use in the presence of flammable anesthetics mixture with air or with oxygen or with nitrous oxide
Mode of operation	Continuous operation with intermittent loading

### ENVIRONMENT PROTECTION AND WASTE DISPOSAL

Disposal information	System contains in some of its parts and subassemblies, solid and liquid substances that must be disposed only designated companies according to local laws
Tube assembly	Beryllium, glass, dielectric oil (PCB free), other metals and plastic
H.V. transformer	Dielectric oil (PCB free), plastic, copper and other metals
Other subassemblies	Plastic, other metals, electronic components, glass, epoxy printed circuits, amorphous selenium

### ENVIRONMENTAL CONDITIONS

Equipment	Transit/Delivery and Storage	Operating with a-Si detector	Operating with a-Se detector
Temperature	- 20 $\div$ + 70 °C	+ 5 $\div$ + 40 °C	+ 20 $\div$ + 25 °C
Relative humidity	10 $\div$ 90 %	30 $\div$ 85 %	30 $\div$ 75 %
Barometric pressure	500 $\div$ 1060 hPa	540 $\div$ 1060 hPa	540 $\div$ 1060 hPa
<b>a-Si Flat Panel Detector</b>	<b>Air transport</b>	<b>Storage and delivery</b>	
Temperature	- 18 to + 70 °C (under 36 h)	- 15 to + 65 °C	
Relative humidity	10 to 85 %	10 to 85 %	
Barometric pressure	540 to 1060 hPa	540 to 1060 hPa	
<b>a-Se Flat Panel Detector</b>	<b>Air transport</b>	<b>Storage and delivery</b>	
Temperature	- 20 to + 60 °C (24 h)	+ 5 to + 40 °C	
Relative humidity	10 to 90 %	10 to 90 %	
Barometric pressure	540 to 1060 hPa	540 to 1060 hPa	
Detector maximum rate of temperature change		10° C in 20'	
Heat dissipated in max load condition of 35 kV 500 mAs (1 shot every 5 minutes)		316 kCal/h	



# MILADY DG

Product Data **Digital mammographic equipment**

## DIMENSIONS

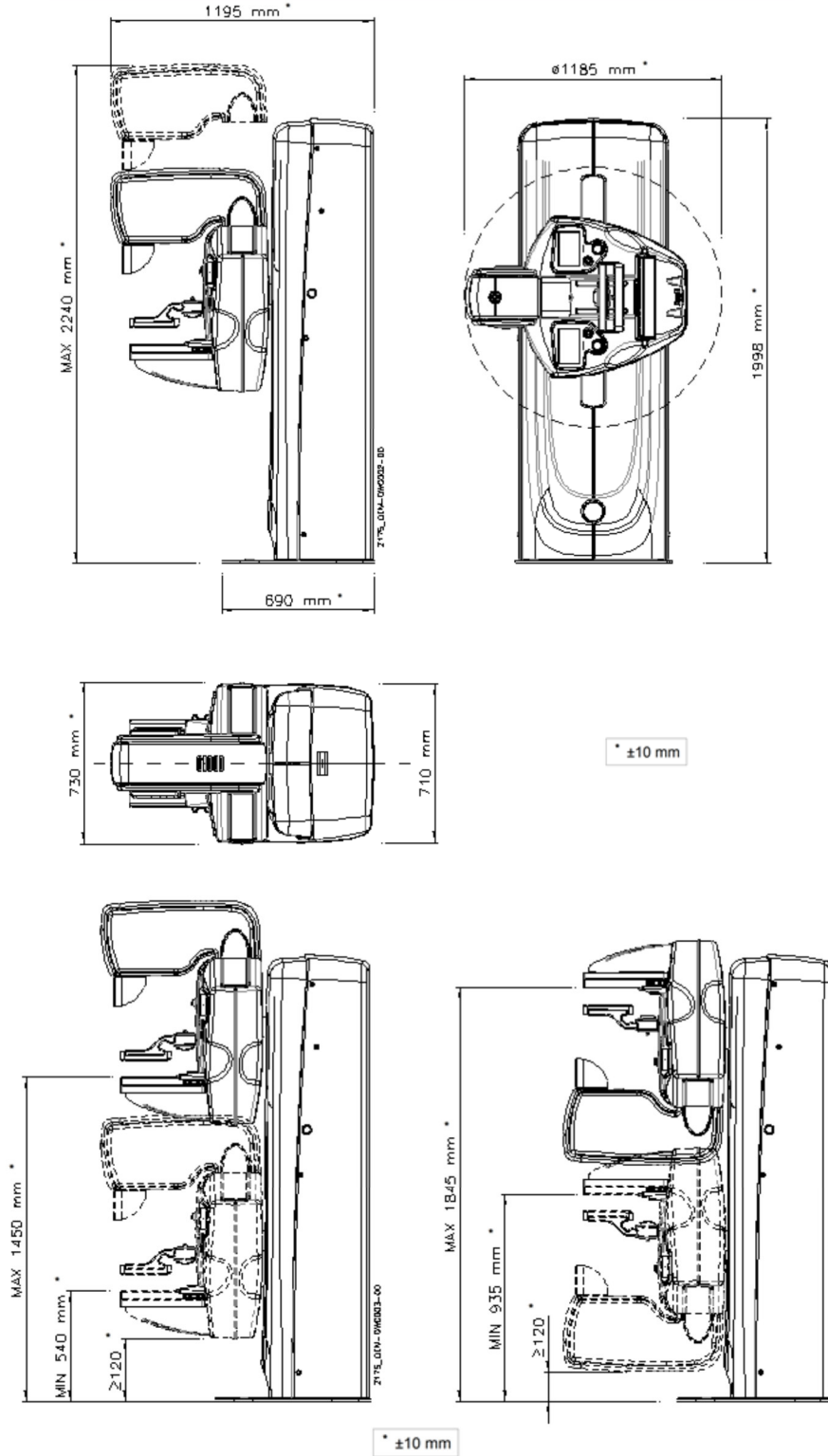



# MILADY DG

Product Data **Digital mammographic equipment**

## DIMENSIONS

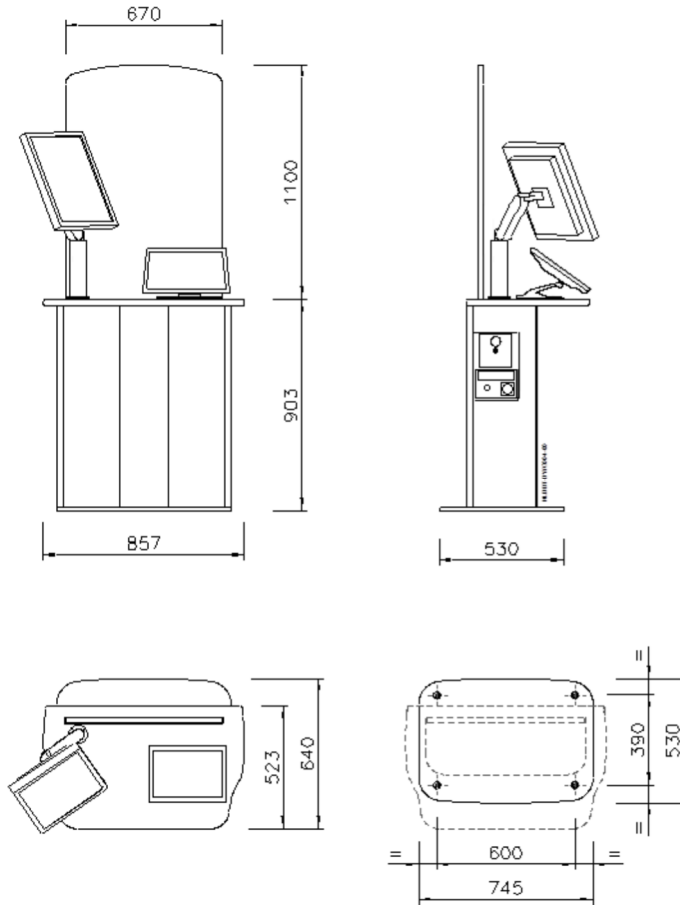

DIMENSIONS IN mm



**ESSE3** srl, Via Garibaldi 30  
 14022 Castelnuovo D.B. (AT)  
 Tel +39 011 99 27 706  
 Fax +39 011 99 27 506  
 e-mail [esse3@chierinet.it](mailto:esse3@chierinet.it)  
 web: [www.esse3.dreamgest.com](http://www.esse3.dreamgest.com)



PD-54-E Rev. 04 - 15.04.2021

**Note:** Specifications are subject to change without prior notice.